

EVODescale

SWISS ENGINEERING 



More information
about the product
on our website!

www.evodrop.com

Flow rate	Max. 50 l/min
Pressure	Max. 8 bar
Weight	3.8 kg
Connections	Inlet and outlet 1 inch flat-sealing thread (no conical thread)
Installation	Drinking water installation according to DIN 1988
Filter	The filter module of the EVODescale demonstrably filters heavy metals as well as bacteria and viruses out of the water.
Germ protection	Our technology sinks metal atoms in the nanoscale into the fibre structure. The resulting electrical potential difference characteristic provides a comprehensive antibacterial and antiviral effect.
Limescale protection	With innovative ion sieve technology consisting of food-grade amino acids, 94% of the limescale in the water is eliminated without the use of salt, waste water or electricity.
Housing	The individual components have been tested in accordance with DVGW guidelines and DIN EN 14898 and are made of food-grade materials. All housing materials fulfil the KTW recommendations and positive lists by using high-quality plastics and metals. The safety tests for pressure resistance comply with DIN 19632, DIN 14898 and GSO 481.1.022.

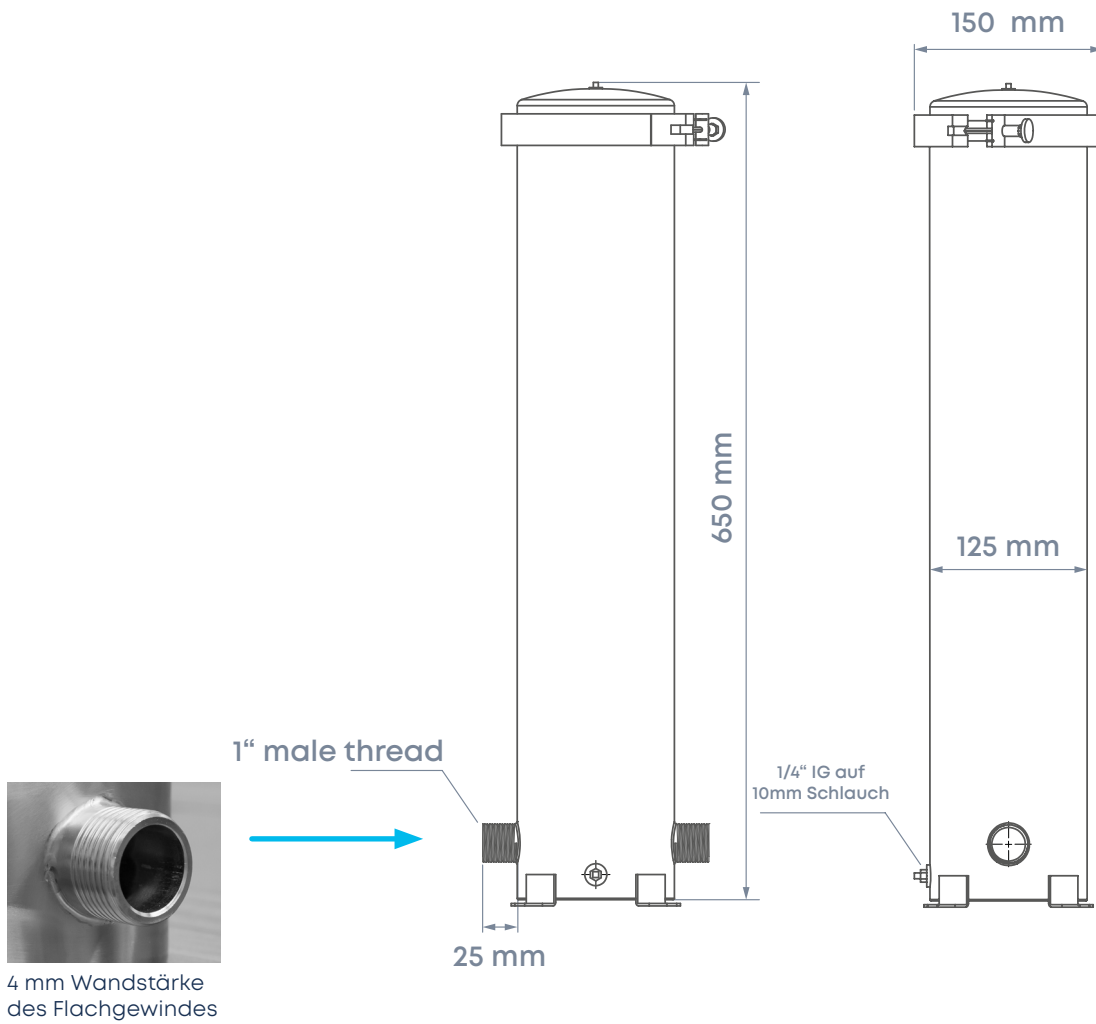

Performance diagram EVodescale

